

How to determine the matching Stahlbus Bleeder Valve

In order to find the **Stahlbus Bleeder Valve** that fits your purposes, you first have to measure the thread of the currently installed bleeder nipple. You may either use a slide gauge or the template printed on this page.

How to measure with the slide gauge

You determine the thread diameter by measuring the external dimensions of the thread with the slide gauge.

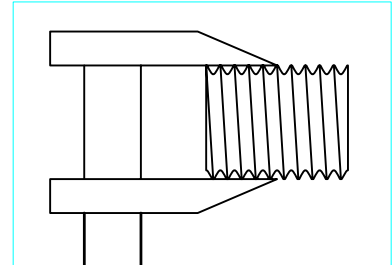

To determine the thread pitch, you measure the length of **four** thread turns with the tips of the slide gauge. Always measure the distance from thread crest to thread crest.

If the value measured is 4 mm, the thread pitch is 1.0; if the value measured is 5 mm, the thread pitch amounts to 1.25.

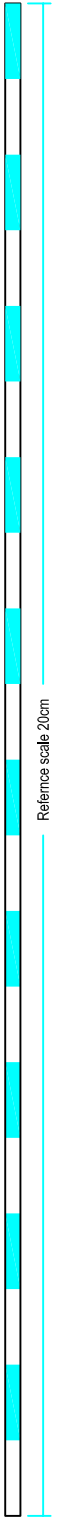
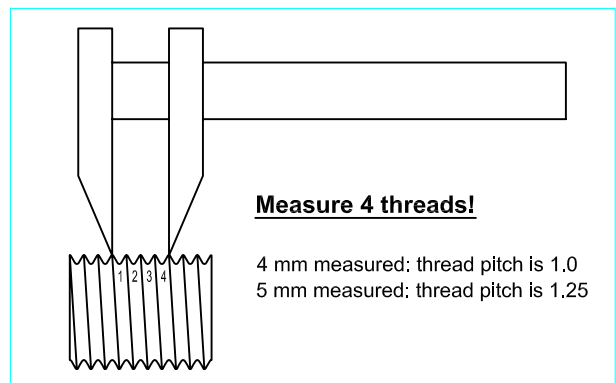

Pictures of threads

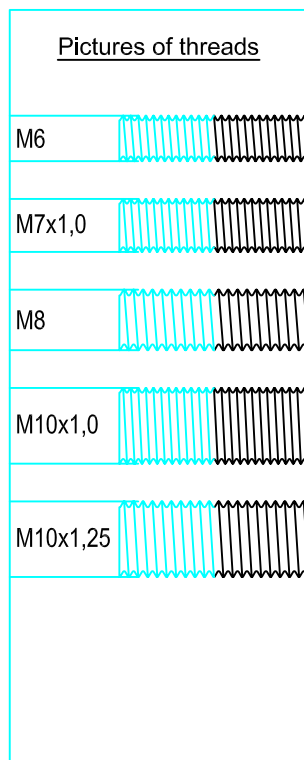

How to measure with the template

To this end, print this page and make sure that it is printed in full size (100 %). To check the correct size of your printout, you may use a ruler to measure the scale on the left side which is 10 cm in length.

Now take the bleeding nipple which is to be substituted by a **Stahlbus Bleeder Valve**. Compare the thread successively to the different printed pictures of threads until you have found exactly that thread which is precisely covered by the valve. Please make sure the template is even and does not wrap itself around the valve.

For valves with a diameter of M10 you have to additionally determine the thread pitch. To do so, please cut out the right corner below where it is marked. Then hold the thread of the valve successively above both sides of the cut-out template for the thread pitch. You have determined the correct pitch if the serrated edges of the thread template exactly match the thread turns.

Thread pitch template

